

CASCADED H BRIDGE MULTILEVEL INVERTER BASED GRID INTEGRATED SOLAR SYSTEM

Aswin P¹, Dr. N. Kaleeswari², N. Arun Prasath³, G. Ranjithkumar⁴ & R. Manivannan⁵

¹PG Student, EASA College of Engineering and Technology, Coimbatore, Tamil Nadu, India

²Professor, EASA College of Engineering and Technology, Coimbatore, Tamil Nadu, India

³Senior Assistant Professor, Department of ECE, EASA College of Engineering and Technology, Coimbatore, Tamil Nadu, India

^{4,5}Assistant Professor, Department of EEE, EASA College of Engineering and Technology, Coimbatore, Tamil Nadu, India

Received: 11 Aug 2022

Accepted: 13 Aug 2022

Published: 25 Aug 2022

ABSTRACT

In the high-power grid-integrated solar energy system (GISES), multilevel inverters are used because they have lower switching losses and harmonics in the injected current. A suitable choice of multiple output dc-dc converters is necessary for the integration of solar PV array with multilevel inverters (MIs). Additionally, there is less research in the literature on two-stage GISES with isolated multi output dc-dc converters and dc-ac multilevel inverters. This article makes effective use of a cascaded H-bridge multilevel inverter with isolated multiple outputs. To provide maximum power extraction under poor irradiation conditions, the isolated multiple output zeta converters is equipped with the maximum power point tracking method, which is based on the firefly algorithm. Through a band stop generalized integral control, active power exchange, and the grid, the power quality is improved.

KEYWORDS: H Bridge Multilevel Inverter, Control Techniques, Algorithms

INTRODUCTION

Due to the finite nature and environmental pollution caused by fossil fuel-based energy generation, renewable energy sources-based power generating is heavily addressed in the electrical power generation sector. Even fossil fuel-rich nations are working to convert to sustainable energy sources while taking the environment's effects into account. Typically, a DC-DC converter and a DC-AC inverter are both included in a two-stage grid-integrated solar energy transmission system. Through the use of maximum power point tracking (MPPT) techniques, the DC-DC converters draw the most solar energy possible from the panels. The fundamental reason for the delayed system response caused by the control methods stated in the grid synchronisation of DC-AC inverters is an increased computing cost.

STATEMENT OF THE PROBLEM

The amount of power generated by solar panels for industrial use does not meet demand. The rising demand for electricity could lead to a power shortage, which would have an impact on traditional generation methods. The generation from solar panels is influenced by a variety of factors. The variables differ due to varying climatic circumstances, time, algorithms, and control methods. The employment of a cascaded H bridge inverter has been the subject of an exploratory analysis in

this work. This study has discovered elements influencing industrial demands, including convenience, product attributes, power quality, and quality.

OBJECTIVES OF THE STUDY

- To identify the factors affecting Solar power Generation
- To analyze the usage of Cascaded H Bridge Multilevel Inverter in Grid connected PV System
- To analyze the impact of Cascaded H bridge MLI in Industrial Power Generation

REVIEW OF LITERATURE

A.A Almehezia and H.M.K Al Masri [1] approach for renewable energy sources integration with the existing grid. Unique types of loads can be demoralized to allow for a sustainable solution to energy integration. A case study of Saudi Arabia is investigated where desalination plants coupled with a water storage tank is utilized to moderate the variability of renewable sources. A hybrid photovoltaic-wind turbine generator system is introduced. The results indicate two critical points. First, even in a fossil fuel rich country, sustainable renewable sources are economically reasonable.

W.Xiao [5] provides review of grid-tied architectures used in photovoltaic power systems, classified by the granularity level at which maximum power point tracking (MPPT) is applied. Grid-tied PV systems can be divided into two main groups that are centralized MPPT (CMPPT) and distributed MPPT (DMPPT).

A.K Podder and N.K Roy [7] introduces an efficient maximum power point tracking (MPPT) method plays an important role to improve the efficiency of a photovoltaic (PV) generation system.

RESEARCH METHODOLOGY

In this investigation, P&O algorithm design was applied. Analyses are done on the overall change to the current system. For this study project, an easy sampling technique is employed. The cascaded H bridge inverter is taken into consideration in this study. For the purpose of gathering secondary data, online journals and books are recommended.

RESULTS AND DISCUSSION

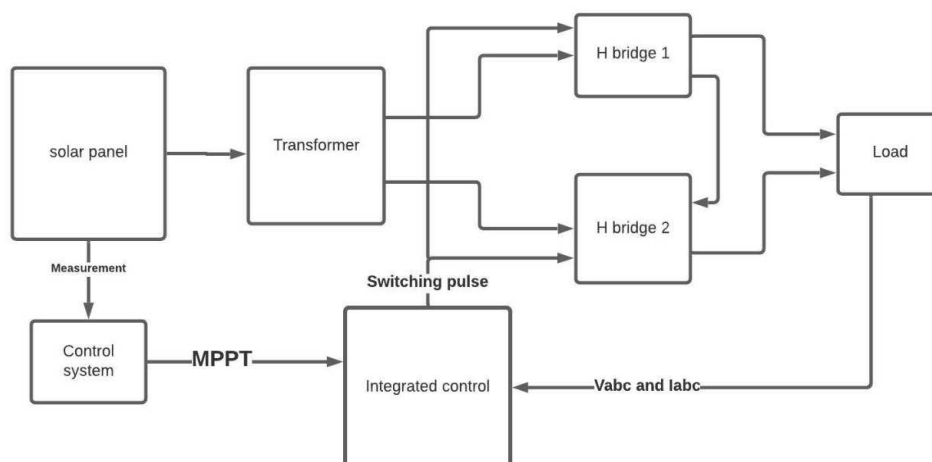

Figure 1

A flyback transformer is a coupled inductor with a gapped core is proposed. During each cycle, energy is stored in the core gap when the input voltage is applied to the primary winding. It is then transferred to the secondary winding to continuously power the load.

Flyback transformers are an excellent choice for low-cost, high-efficiency isolated power supply designs up to about 120W, offering circuit isolation, multiple output possibilities, and the possibility of positive or negative output voltages. It can also be standardized over a wide range of input voltages and load conditions. Because the energy is stored in the transformer, the flyback topology does not require a separate output filter inductor like other isolated topologies, which is one of its main advantages of this system

This reduces component count and simplifies circuit requirements. This article analyzes flyback transformers and the applications they are best suited for. The Cascaded H-Bridge Multilevel Inverter requires a minimal number of components at each level and requires capacitors and switches to build. This topology consists of a series of power conversion cells and its performance can be easily measured.

The combination of capacitors and switch pairs is called an H-bridge and provides a separate DC input voltage for each H-bridge. It consists of H-bridge cells, each cell outputs three different voltages such as zero, positive DC and negative DC. One of the advantages of this type of multi-level inverter is that it requires a minimal number of components compared to the diode-clamped inverters with flying capacitors that are commonly used. The cost and weight of the inverter are lower than the two level inverter. Soft switching is possible through several advanced switching methods.

The multilevel converter has several advantages, some of them are:

Common Mode Voltage

The multilevel inverters produce common-mode voltage, minimizing the stress of the motor and prevent damage to the motor.

Input Current

Multilevel inverters use input current with low distortion

Switching Frequency

It can operate at both fundamental switching frequencies that are higher switching frequency and lower switching frequency. It should be noted that the lower switching frequency indicates lower switching loss and higher efficiency.

Reduced Harmonic Distortion

The multi-level topology combined with the selective harmonic rejection technology results in low total harmonic distortion of the output waveform without the use of filter circuits. Circuit configuration of the proposed grid-connected photovoltaic power generation system "GISES". His two-stage GISES consists of a two-output Zeta converter as the DC-DC converter stage and a modular symmetrical cascaded H-bridge array as the inverter stage. The three phases are powered by the same photovoltaic system. This article describes a 5-level MI with two H-bridges. Sa1 to Sa4 are the upper H-bridge switches and S0 a1 to S0 a4 are the lower H-bridge switches. Single Input Multiple Output Zeta (SIMO Zeta) converters are used as DCDC converters in each phase and the input to these converters is taken from a single PV array. Many publications use a single DC-DC converter at the input of the H-bridge. However, this SIMO structure is used to

ensure balanced power injection in each phase, making the system simpler with a single MPPT algorithm. The SIMO-zeta also produces constant isolated and equal intermediate circuit voltages (V_1 and V_0). It also reduces power conversion

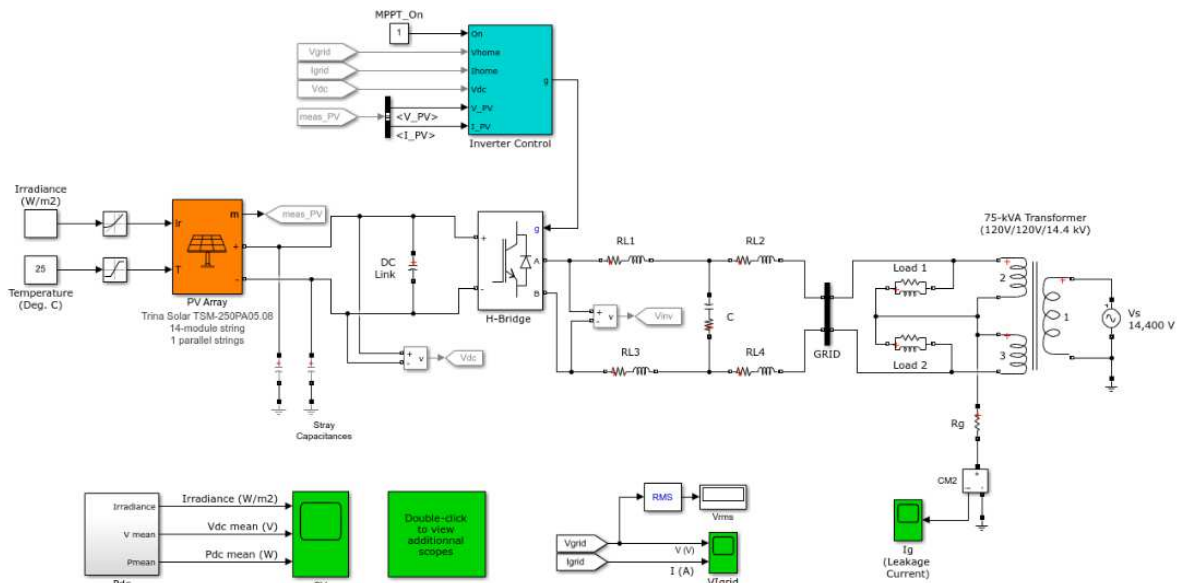

Figure 2

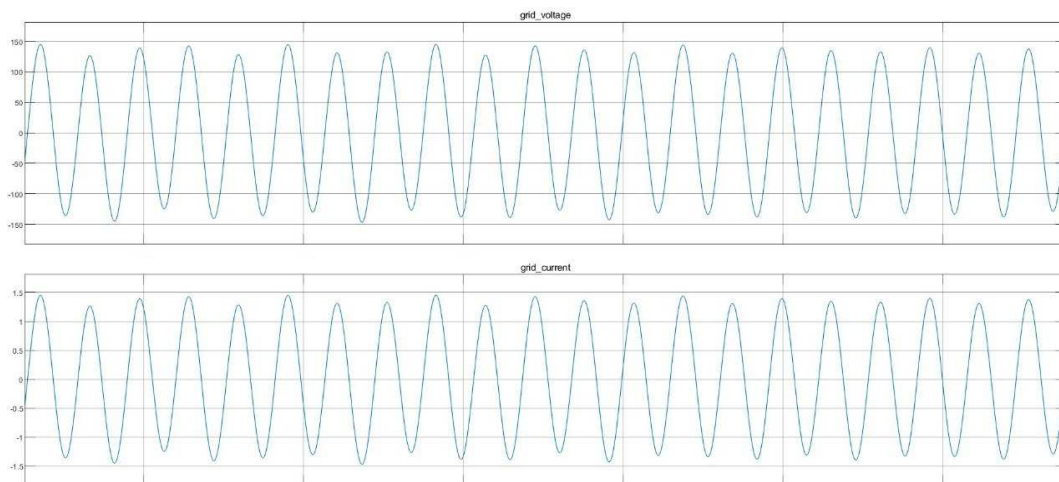

Figure 3: Output Voltage of H Bridge 1 and 2

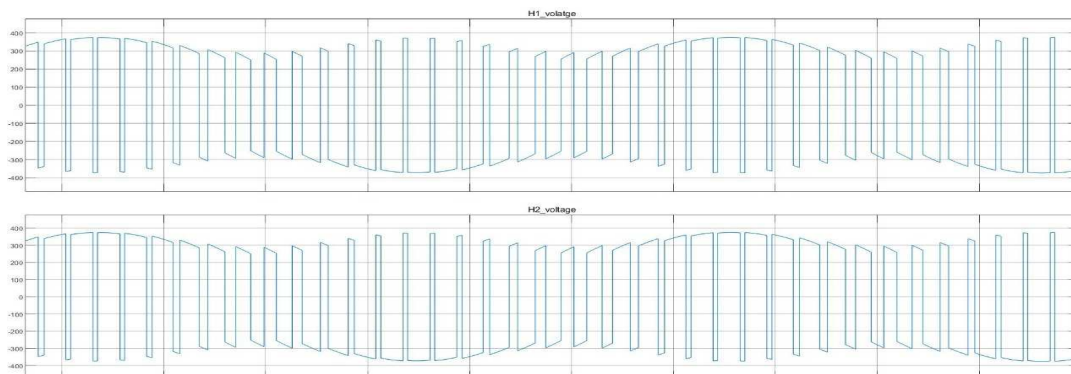

Figure 4

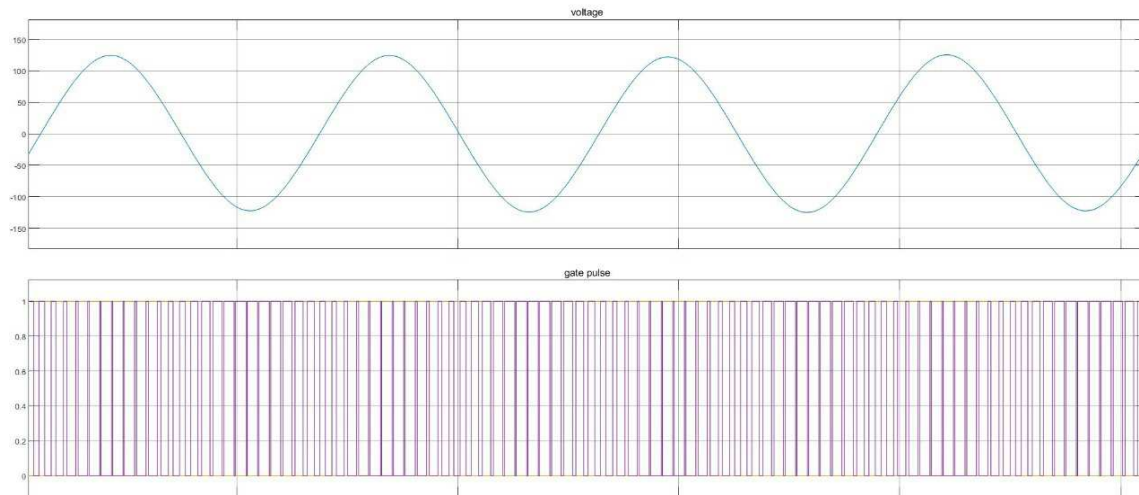

Figure 5

CONCLUSION

In order to get maximum power from the PV module, this document implements mppt based on the modified p&o algorithm. The hardware consists of a highly efficient step-down DC/DC converter and his MPPT controller based on a microcontroller and tested to charge the battery. Compare a conventional charge controller and a designed charge controller for charging a 12V battery from a 200W photovoltaic panel. This shows that the modified p&o algorithm provides efficient and reliable maximum power tracking performance under abrupt changes in irradiance and temperature conditions. Experimental results show that the proposed system is more efficient than conventional designs. Two-tier grid-integrated solar energy system 'gises' This work demonstrates the use of cascaded H-bridge multilevel inverters (chbmi) and isolated multi-output zeta converters.

A full simulation and prototype model of a 5-level cascaded H-bridge inverter is proposed in this white paper. The prototype model consists of a cascaded 5-level H-bridge inverter power circuit, a PIC microcontroller and a PV panel.

Balanced power sharing operation at lower switching frequencies achieves inch bmi for higher power rated applications to reduce switching losses. MPPT control based on the firefly algorithm realizes high-speed and accurate operation accompanying changes in solar radiation. A generalized integral (bsgi) bandstop control algorithm has been demonstrated for integration into gratings. The bsgi-based grid integration of the multi-level inverter allows the system to operate under unfavorable grid conditions; reactive power compensation, harmonic mitigation, grid current balancing, and DC offset rejection in addition to live power supply. System response is verified using steady-state analysis under balanced and unbalanced linear/nonlinear load conditions and various irradiance levels. This agrees well with theoretical claims. Dynamic performance has been found to be satisfactory in the presence of mains voltage drops/surges, load imbalances, and insulation fluctuations. Oscillation and overshoot at transition state are not observed.

REFERENCES

1. F. de Melo, W. D. Vizzotto, P. J. Quintana, A. L. Kirsten, M. A. Dalla Costa and J. Garcia, "Bidirectional Grid-Tie Flyback Converter Applied to Distributed Power Generation and Street Lighting Integrated System," *IEEE Tran. Ind. Appl.*, vol. 51, no. 6, pp. 4709-4717, Nov. 2015

2. W. Xiao, M. S. El Moursi, O. Khan and D. Infield, "Review of grid-tied converter topologies used in photovoltaic systems," *IET Ren. Power Gen.*, vol. 10, no. 10, pp. 1543-1551, Nov., 2016.
3. V. Bist and B. Singh, "A Brushless DC Motor Drive with Power Factor Correction Using Isolated Zeta Converter," *IEEE Tran. Ind. Inform.*, vol. 10, no. 4, pp. 2064-2072, Nov.2014.
4. A. Malhotra, P. Gaur, S. Vij and C. Malhotra, "Design, analysis and performance of zeta converter in renewable energy systems," *Proc. Int.Conf. Computing for Sustainable Global Development (INDIACom)*, NewDelhi, pp. 2487-2491,2016.
5. A. K. Podder, N. K. Roy and H. R. Pota, "MPPT methods for solar PV systems: a critical review based on tracking nature," *IET Ren. Power Gen.*, vol. 13, no. 10, pp. 1615-1632, July,2019.
6. D. F. Teshome, C. H. Lee, Y. W. Lin and K. L. Lian, "A Modified Firefly Algorithm for Photovoltaic Maximum Power Point Tracking Control Under Partial Shading," *IEEE Journ. Emerg. and Selected Topics in Power Electron.*, vol. 5, no. 2, pp. 661-671, June2017.
7. K. Sundareswaran, S. Peddapati and S. Palani, "MPPT of PV Systems Under Partial Shaded Conditions Through a Colony of Flashing Fireflies," *IEEE Tran. Energy Converter.*, vol. 29, no. 2, pp. 463- 472, June2014.
8. Yu, T. and Wu, G, (2007), "Determinants of internet shopping behavior: An application of reasoned behavior theory", *International Journal of Management and studies*, Vol.24, No.4, pp.744-762, 823.
9. N.Arun Prasath, N.Kumaresan," A Novel Approach on Greedy Maximal Scheduling Algorithm on Embedded Networks," *Networks and Complex Systems (IISTE)*, Vol.5,Issue 3,pp 15-20,March 2015
10. N.Arun Prasath, N.Kumaresan," Vehicle Speed Measurement and Number Plate Detection using Real Time Embedded System," *Networks and Complex Systems (IISTE)*, Vol.5,Issue 3,pp 15-20,March 2015
11. N.ArunPrasath, N. Kaleeswari, "Energy Efficient and Timing Error Mitigation Circuit Design Based on Clock Adjustment," *Jundishapur Journal of Microbiology*,Vol.15,Issue 1,April 2022.
12. N.ArunPrasath, N. Kaleeswari, "Improved method for channel estimation in MIMO OFDM" *International Journal of Research in Engineering and Technology*,Vol10,Issue6,page:17-24,June 2022.
13. N.ArunPrasath, N. Kaleeswari, "A Novel beam forming algorithm for Massive MIMO System using Kalman Formulation with Deep Learning" *International Journal of Research in Engineering and Technology*, Vol 10, Issue6,page:9-16,June 2022.
14. N.ArunPrasath, "High performance MAC Based on Multi-Level Approximte compressors with Balanced Error Accumulation" *International Journal of Research in Engineering and Technology*,ISSN:2347-4599,Vol10,Issue6,page:1-8,June 2022